

Model: rdc485ic

RS-232 to RS-485 isolated converter

The rdc485ic safely connects RS-232 devices to 2 or 4-wire RS-485 devices without danger of ground loops and damaging surges. The data signals have 2.5kV optical isolation. Internally isolated DC supply provides 2-port galvanic isolation, or full 3-port can be ordered so both the RS-232 and RS-485 signals float with respect to the power supply ground. Jumpers allow internal 120Ω terminating resistor.

600w transient (spike) suppressor diodes are standard on isolated ports; 9-pin D-sub shell or removable 5-pin compression terminal block; DC supply of 5, or 9 to 36v; 2 or 3-port galvanic isolation; custom terminating resistor values.

Isolation, industrial design, small size, DIN rail mount, user indication, and DC supply make the rdc485ic a very engineer-friendly device for your industrial data communication system.

Specification

Ports	RS-232	RS-485
Signal Type	EIA/RS-232E	EIA/RS-422A & RS-485A
Voltage Level	+/- 9 vDC	-7 to +12vDC
Permitted Surge	+/- 25 vDC	+/- 25 vDC

Isolation (ISO/IEC 9549)

RS-232 to RS-485: 2500 v (optical, 5kV test)
 Supply to RS-485.....: 2500 v (galvanic, 3kV test)
 Supply to RS-232.....: 2-port = none ; 3-port = 500v

Power Supply:

9 to 36v DC,
 5v DC +/- 10%,
 LEDs (green) indicate isolated power status

Communication:

Max Speed: at least 115Kbps at standard distances
 Character Setting: transparent, no configuration required
 User Indications: Each receive signal has LED (yellow)
 Standard Distance ...: 15m for EIA/RS-232; 1000m for EIA/RS-485
 Practical Distance ...: less than 50m for RS-232, 3000m for RS-485
 (requires quality, low-cap cable < 50 pf/m)

Mechanical / Environment

Operating Range ...: -40C to +65C
 Storage Range: -40C to +100C
 Relative Humidity ..: 10 to 90% RH, non-condensing
 Terminals: wire up to 2.5mm (12 AWG)
 D-shell connector...: 9-pin, 30μ gold pins/sockets rated 500 cycles
 Case Material: nylon polyimide, fungus and termite resistant
 self-extinguishing
 Weight: approx 130g
 Mounting Rail: DIN EN 50 022 or DIN EN 50 035

Copyright © 1997-2000 RDC

Specifications subject to change without notice.

RS-232 to RS-485 Isolated Converter

Block Diagram

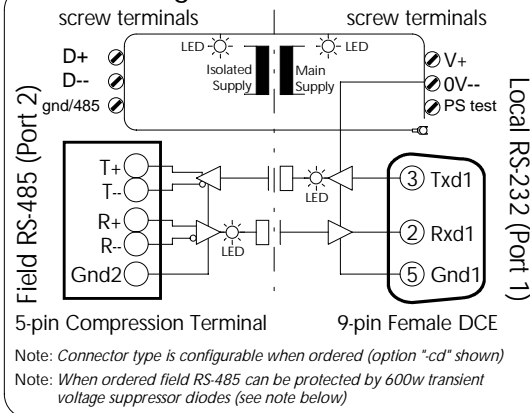

Order Information

rdc485ic - [] - [] - [] - []

Term Resistor Value
 nnn = custom value
 [] * 120Ω

Connector Configuration
 cc = Compression terminal (C-term) both ports
 cd * = C-term RS-485, D-sub female RS-232
 dd = D-sub female for both ports

Galvanic Isolation Configuration
 2p = 2-port, RS-232 sgnd = DC supply ground (5v only)
 3p * = 3-port, 500v isolation between RS-232 & supply

Power Supply Configuration
 5v = 5v +/- 10% DC Supply
 dv * = 9 to 36 vDC Supply
 hv = 48 VDC +/- 20% 1 watt

* shows factory default options

Dimensions in mm (and inches)

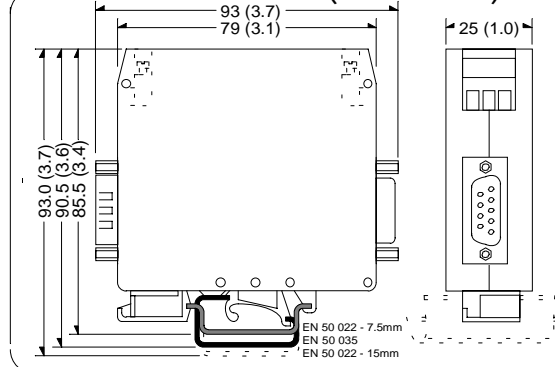

www.robustdc.com

